

Maximum Thickness  
 $9/16"$   
 14mm

Attention  
 Reverse Threaded  
 For Tamper Proof Purposes

SECTION E-E  
 SCALE 2 : 1  
 M8 Thread

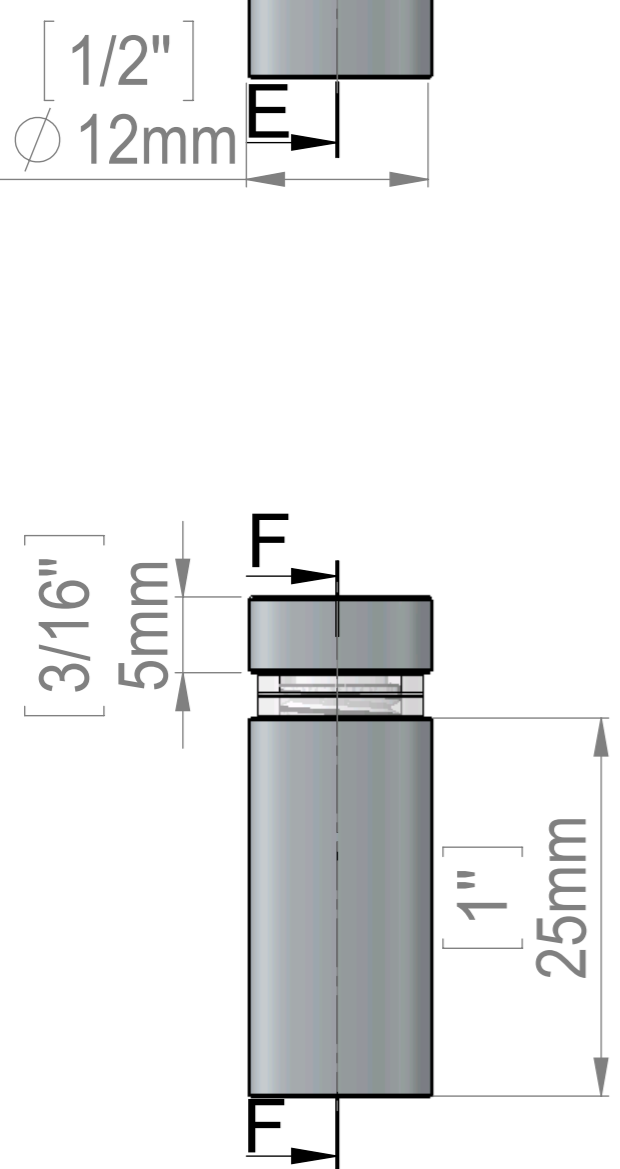

SECTION F-F  
 SCALE 2 : 1

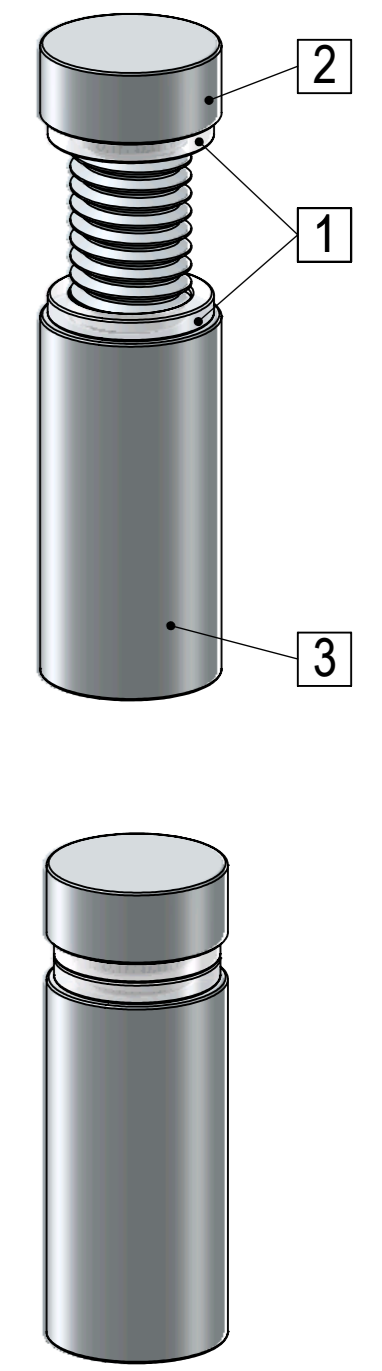

ITEM NO.	PART NUMBER	DESCRIPTION	QTY.
1	FAH12_Washer		2
2	HM1102A(FHA12-25)-Reverse_Thread		1
3	FAH12-30_Body-12x25-Reverse_Thread		1

Title : FAH12-30		Scale : 2:1		
		Sizes : Letter Landscape	Customer:	
Material:		Finish	Qty :	Rep :
N°programme laser		N°prog. Mécanum.	N° Plan : FAH12-30	